

**The  
Andersons**

# **Model LCO-1000**

*Professional Rotary Spreader*

## **Assembly, Use and Care**

### **Thank You!**

You have purchased the highest quality professional broadcast spreader available on the market today. The LCO-1000 is the accumulation of proven performance and will provide you with years of trouble-free service. In the event you should have any questions or comments, please call our professional support staff.

Our toll-free number is **1-800-225-2639** (U.S. Only)

### **Before You Begin ...**

To assemble your new spreader, we highly recommend that you read all the instructions thoroughly, familiarize yourself with the assembly and components, and verify that all parts are included in the package.

### **You Will Need ...**

The following tools:

- 7/16" open-end wrench  
(or adjustable wrench)
- Pliers
- Grease gun



# Assembly

- 1)** Turn the spreader upside-down. Place the wheels on the axle with the longer portion of the hubs facing inward. Secure the drive wheel "A" (right side) to the axle using the 3/16" cotter pin. Attach the idler wheel "B" (left side) to axle. Then insert the 1/8" cotter pin through the axle and secure.

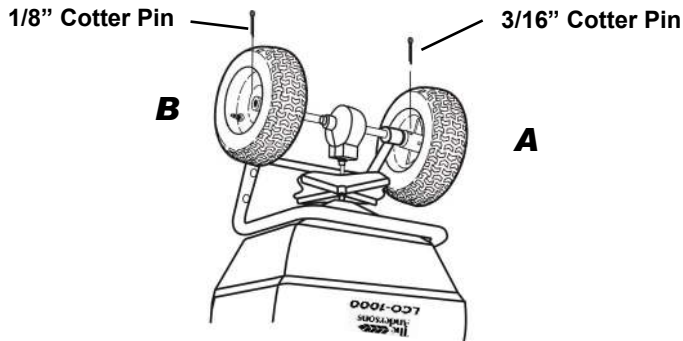

- 2)** Attach the leg/brace to the frame as shown using (4) 1/4-20 x 2 1/4" carriage bolts and lock washers, and nuts.

Place a drop of oil on bolt threads to ease assembly of locknuts

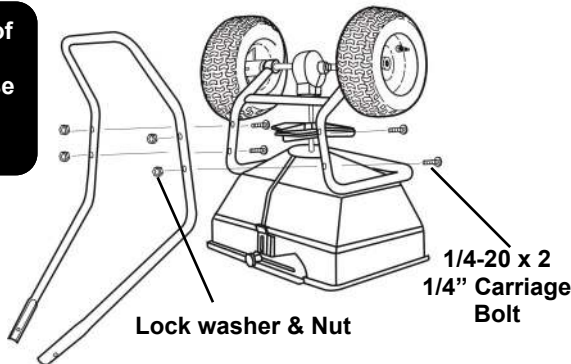

- 3)** Turn spreader upright on wheels. Insert screen into hopper sliding it under the screen clips. Attach the upper handle assembly to the handle brace with the handle lever facing as shown. Secure with (2) 1/4-20 x 1 1/2" carriage bolts, lock washers, and nuts. Using a grease gun, lubricate the grease fittings on the axle.

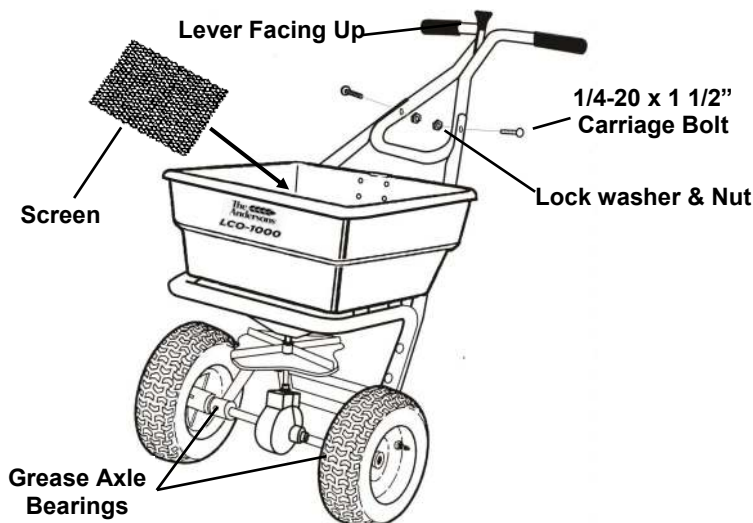

- 4)** Install control tube to the handle lever with (1) 1/4 dia. clevis pin and a 3/32" dia. cotter pin. Remove the paper tube on the end of the lower control rod and slip opposite end of control tube over the rod making sure the pivot lever is between the lower rod and the control tube. Secure with a hitch pin cotter.

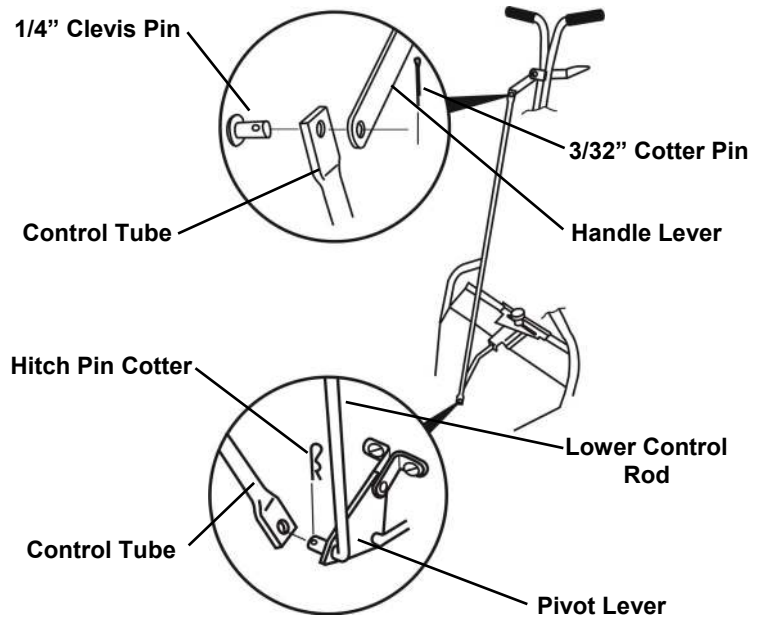

- 5) CHECK SPREADER FOR COMPLETE SHUTOFF.**

Pull the on/off control lever back to the "OFF" position. Determine if the holes in the hopper are completely closed as shown below. Also make sure shut off plate is not closing too far which will cause the control lever to bind. If adjustment is needed, loosen the two carriage bolts holding the upper handle to the leg/brace assembled in step #3. The holes in the handle are slotted to allow the upper handle to be moved. Slide the upper handle toward the hopper to increase the shutoff, move handle in the opposite direction to reduce shutoff. Re-tighten bolts and recheck shutoff.

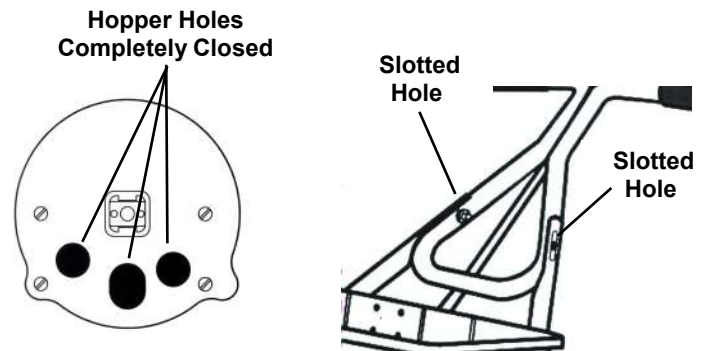

# Operation

## HOW TO USE

- 1) Check product bag for rate setting (letter), and swath width. The rate setting is achieved by loosening the rate control knob and sliding the rate control plate until the pointer aligns with the desired letter.
- 2) Pull the main shutoff lever to the closed position before filling the hopper.
- 3) Start rolling the spreader forward before opening the ports: close ports before stopping.
- 4) Hold the handle so the hopper is level. Tipping the spreader to far forward or backward will cause uneven spreading.
- 5) Use the swath width recommended on the bag for your model and push the spreader at 3 MPH (a brisk walking pace). Apply material in the forward direction only-not while pulling.
- 6) The settings given on the product label are recommended starting points. **Test rate and pattern on a small area before treating a large area. Actual application rate can vary depending on weather, spreader conditions, and walking speed.**
- 7) A hopper cover is provided with your new spreader. Use it to protect the turf product inside the hopper from light rain or windy conditions during use and transportation.

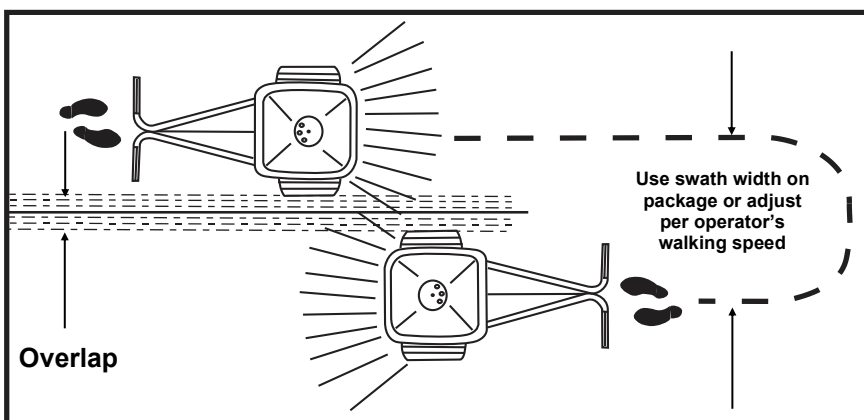
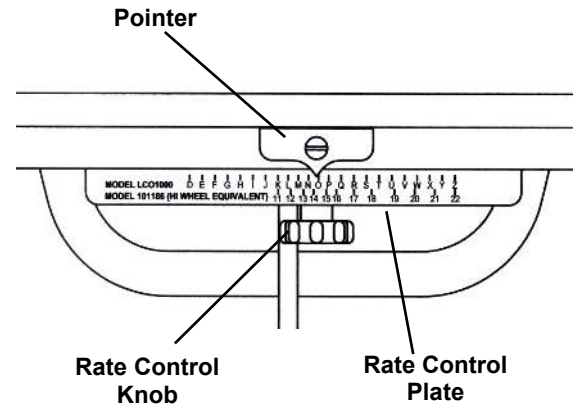

# Maintenance

- 1) Empty the spreader after each use. Return the unused material to its original container and seal to prevent moisture-caused clumping.
- 2) Wash the spreader thoroughly. Let spreader dry in a sunny or heated area. Wipe or blow off excess water to prevent corrosion. Clean all residue from the rotor plate.
- 3) Periodically grease the axle bearing housings and apply a few drops of oil to the impeller shaft bearing as shown below.
- 4) Periodically oil the pivot points on all control linkage and the spring inside the rate control housing.
- 5) Periodically clean and inspect the gears by removing the gearbox cover halves. Apply a small amount of grease to fittings on the gear carrier and the gear teeth for lubrication. Be sure to reinstall the gearbox cover halves prior to use.

- 6) Gear mesh should be checked on a regular basis during high use periods. Clearance between the axle gear and pinion gear should be minimal but not tight. If adjustment is necessary, loosen axle collar set screw and hold gears together. Slide axle collar against the gear support and tighten axle collar set screw. Spin drive wheel. Gears should run freely and smoothly.
- 7) Maintain tire pressure at **20 psi maximum**.
- 8) If the axle requires disassembly, be sure to reassemble it so the drive wheel attaches on the right side as you push the spreader. Incorrect spread pattern will result if the rotor plate does not rotate in a counter-clockwise direction.

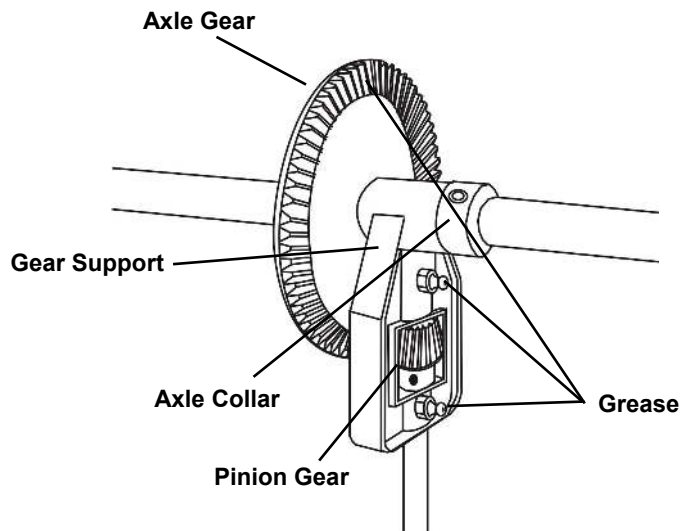

# Calibration Instructions

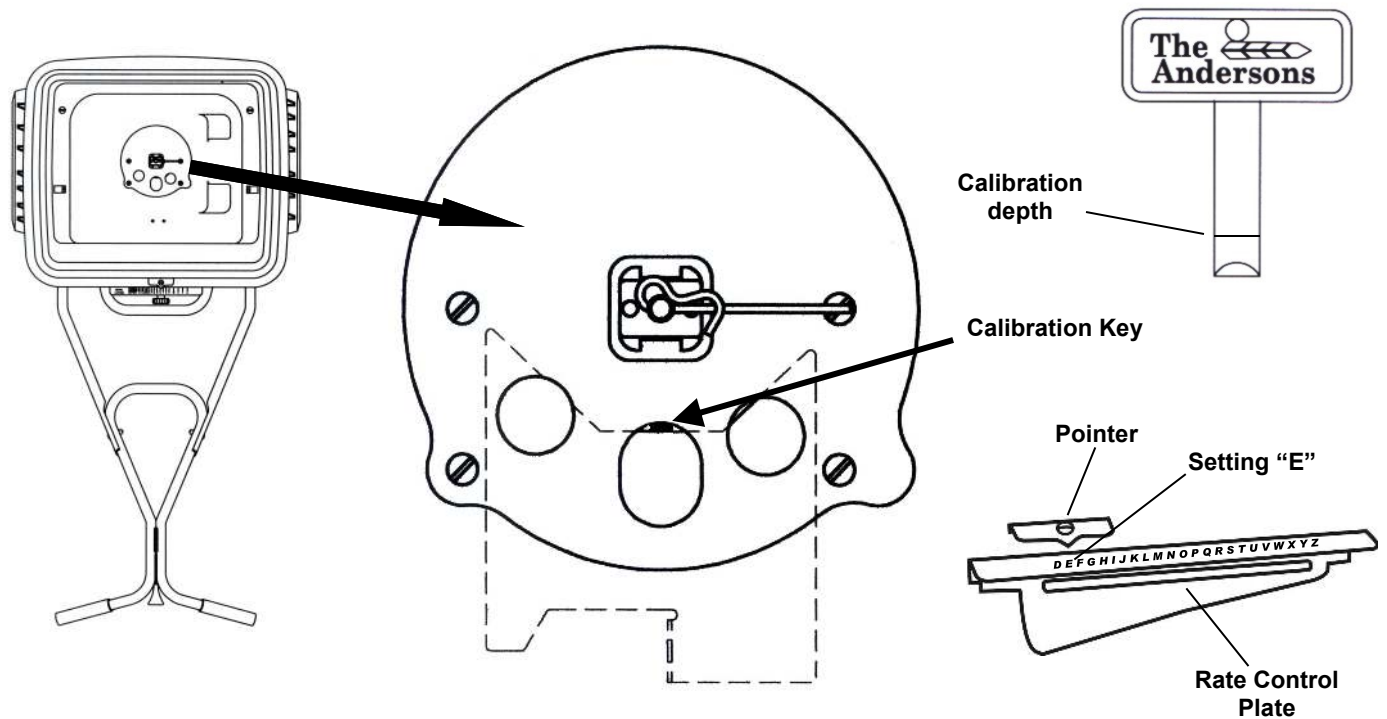

***Your professional spreader has been factory calibrated. For best results, occasionally check calibration and adjust if necessary.***

- 1) Pull the main shutoff lever to the closed position.
- 2) Set the rate control plate to the "E" setting.
- 3) Push the main shutoff lever to the open position.
- 4) Insert the Calibration Key vertically into the center port hole, as shown above.
- 5) If the calibration key fits snugly, the spreader is properly calibrated. If not, continue with steps 6-13.
- 6) Loosen the rate control knob and slide the rate plate all the way to the left.
- 7) Insert the calibration key as described in Step #4.
- 8) Pull the main shutoff lever to ease the shutoff plate against the calibration key. Use the main shutoff lever to hold the calibration key in place.
- 9) Slide the rate control plate to the right until it comes in contact with the protruding end of the rate control rod.
- 10) Tighten the rate control knob.
- 11) Remove the calibration key and pull the main shutoff lever to the closed position.
- 12) Loosen the nuts securing the rate control pointer and slide the pointer so that it centers on the "E" setting of the rate control plate
- 13) Re-tighten the screw on the pointer.

# Parts Diagram-LCO-1000

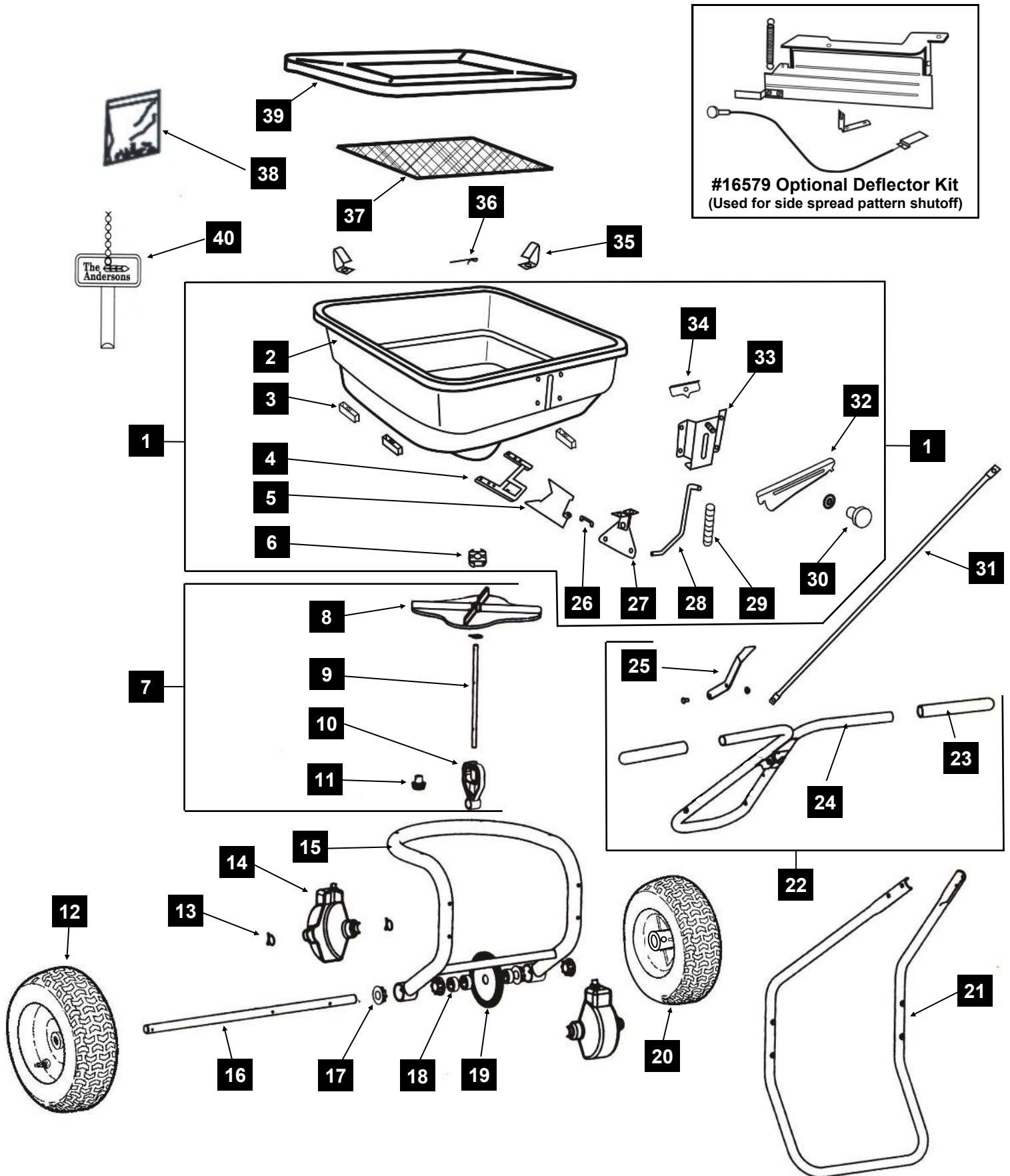

#16579 Optional Deflector Kit  
(Used for side spread pattern shutoff)

# Ordering Parts

See diagram for assistance in identifying specific parts.

For parts orders, call 1-800-294-0671. (Note: Sales of parts for the Andersons spreaders are handled by EarthWay. **IMPORTANT:** When ordering replacement parts, always provide the following information:

- 1) Part number (DO NOT use key numbers when ordering parts. ALWAYS use part numbers.)
- 2) Part description
- 3) The Andersons model LCO1000 (product code ASPLCO1000)

KEY #	PART DESCRIPTION	PART #
1	Hopper Assembly	16591
2	Hopper *	16592
3	Hopper Spacer (set of 4)	16603
4	Shutoff Plate Guide *	14836-1
5	Shutoff Plate *	16594
6	Impeller Shaft Bearing Assembly *	14312-1
7	Impeller Assembly (includes #8 thru #11)	16596
8	Impeller	16597
9	Impeller Shaft	16598
10	Gear Carrier, Complete w/ Grease Fittings	780155
11	Pinion Gear	780122
12	Idler Wheel	14857
13	Retainer Clip (set of 3)	780180
14	Gearbox Cover Half (set of 2)	780110
15	Frame Assembly (includes #17)	16600
16	Axle	16599
17	Axle Bearing (set of 4)	16412
18	Axle Collar (set of 3)	780200
19	Ring Gear	780121
20	Drive Wheel	14856
21	Rest	16604
22	Upper Handle Assembly (includes #23 & #25)	15512
23	Hand Grips (set of 2)	14870
24	Upper Handle	15498
25	Main Shutoff Lever Assembly	15513
26	Shutoff Plate Link *	14846
27	Pivot Lever Assembly *	14878
28	Lower Control Rod w/ swivel *	14917
29	Rate Control Spring *	13354
30	Rate Control Knob/Washer *	12704
31	Control Tube	14916
32	Rate Control Plate *	16595
33	Rate Control Housing *	15527
34	Pointer *	12708
35	Hopper Screen Clip (set of 2)	780440
36	Agitator Pin	780100
37	Hopper Screen	14863
38	Fastener Pack	15579-1
39	Hopper cover	14606-1
40	Calibration Key (see calibration instructions)	15740
—	Optional Side Deflector Kit (Product Code SDSHIELDLCO)	16579

\* Indicates parts in Hopper Assembly



**For More  
Information  
Call . . .**

**1-800-225-2639**  
(U.S. Only)

The Andersons' toll-free  
Helpline. This helpline is  
provided to give you more  
Information about  
Andersons Turf Products.



**Or Visit Our  
Website At ...**  
[www.andersonsturf.com](http://www.andersonsturf.com)

The Andersons, Inc.  
480 Dussel Drive  
Maumee, OH 43537 USA

# Warranty

---

## The Andersons warrants to Purchaser the following:

1. Product will be free of defects in materials and workmanship for a period of one year from date of purchase.
2. The axle gear, gear support, pinion gear, axle, and axle bearings have a limited lifetime warranty to be free of defects in materials and workmanship.
3. If the spreader is used for commercial rental the Limited Warranty shall be limited to a period of 90 days.
4. All Unit and part replacement will be performed at the reasonable discretion of The Andersons and EarthWay.
5. Labor charges are not covered and the unit need not be returned to the dealer for warranty service.
6. Proof of purchase must be supplied to The Andersons.
7. For warranty questions, contact EarthWay at 1-800-294-0671.

The Andersons sole obligation under this warranty is limited to repairing or replacing the defective part.

This warranty does not extend to any Product or parts thereof that have been allowed to corrode, subjected to misuse, neglect, accident, or modification by anyone other than The Andersons or that have been affixed to any nonstandard accessory attachment or that have been used, stored, installed, maintained operated in violation of The Andersons instructions or standard industry practice. No agent, employee or representative of The Andersons has any authority to bind The Andersons to any affirmation, representation or warranty concerning the Product and any affirmation, representation or warranty made by any agent, employee or representative shall not be enforceable by Purchaser.

**THIS WARRANTY EXTENDS ONLY TO THE ORIGINAL PURCHASER AND IS EXPRESSLY IN LIEU OF ANY OTHER EXPRESS OR IMPLIED WARRANTIES, INCLUDING WITHOUT LIMITATION ANY IMPLIED WARRANTY OR MERCHANTABILITY OR FITNESS OR INTENDED USE FOR A PARTICULAR PURPOSE AND OF ANY OTHER OBLIGATION ON THE PART OF The Andersons. The Andersons SHALL NOT BE LIABLE FOR ANY INCIDENTAL, SPECIAL OR CONSEQUENTIAL LOSS, DAMAGE OR EXPENSE DIRECTLY OR INDIRECTLY ARISING FROM THE USE OF ANY OF THE PRODUCT INCLUDING, BUT NOT LIMITED TO, DAMAGE OR LOSS OF OTHER PROPERTY OR EQUIPMENT, LOSS OF PROFITS OR REVENUE, COST OF CAPITAL, COST OF PURCHASED OR REPLACEMENT GOODS, OR CLAIMS OF CUSTOMERS OF PURCHASER.**



It is our first priority to improve our products' quality  
and performance whenever possible.

Your comments and questions are always welcome-

Please call our Helpline: **1-800-225-2639**  
(U.S. Only)

**Or Visit Our Website At ...**

[www.andersonspro.com](http://www.andersonspro.com)

**The Andersons, Inc.  
480 Dussel Drive  
Maumee, OH 43537**