

# 2150 COMMERCIAL BROADCAST SPREADER ASSEMBLY and OPERATING INSTRUCTIONS

**EarthWay®**  
EV-N-SPRED

**PLEASE CALL IF YOU ARE MISSING ANY PARTS, HAVE ANY DIFFICULTY IN ASSEMBLY, OR HAVE ANY QUESTIONS REGARDING THE SAFE OPERATION OF THIS SPREADER. THIS MODEL INCLUDES *LIFETIME TECHNICAL SUPPORT* SUPPORT HOT LINE: 574-848-7491 or 800-294-0671, email: techsupport@earthway.com**

## HELPFUL HINTS: READ THE DIRECTIONS BEFORE ASSEMBLY

- ☑ If your spreader does not spread evenly, be sure the FRONT on the gear box points to the front of the spreader. The impeller must turn clockwise. Reversing the gearbox will cause the impeller to turn counter clockwise. Clean the impeller plate after each use. Fertilizer stuck on the impeller blades will cause uneven spreading.
- ☑ Your spreader is designed to be pushed at three miles per hour, which is a brisk walking speed. Slower or faster speeds will change the spread patterns. Wet fertilizer will also change the spread pattern and flow rate. Clean and dry your spreader thoroughly after each use. Coat all metal surfaces (*inside & outside of tubing*) with light oil or silicon spray to help prevent corrosion. Wash between the shut off plate and bottom of the hopper. **Do not use powdered materials.**
- ☑ Gears are permanently lubricated at the factory. Do not open the gearbox or dirt may enter.

## IF YOUR SPREADER COMES SEMI ASSEMBLED, SKIP TO STEP #7

**ROCK SALT and POWDERED MATERIALS should not be used in this spreader as it will damage the gearbox and can void the warranty. Use only granular materials.**

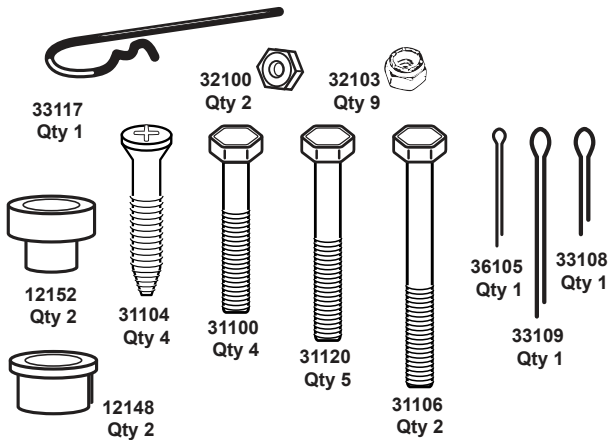

1. Remove and identify all loose parts from carton.

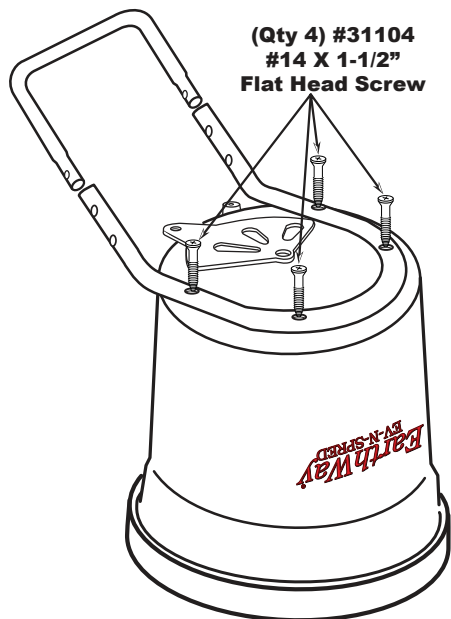
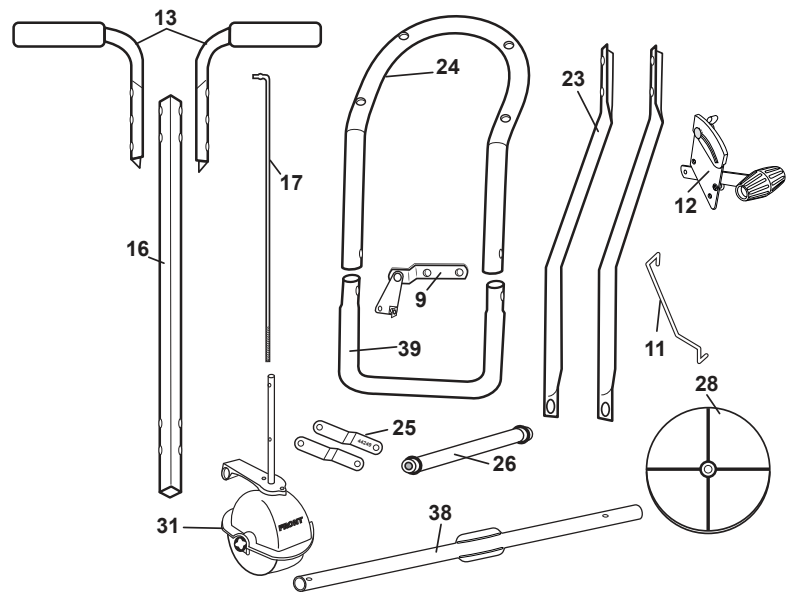

2. Position hopper on side. Install frame using (4) #14 x 1½" Flat Head Phillips screws. **TIGHTEN THESE NOW**



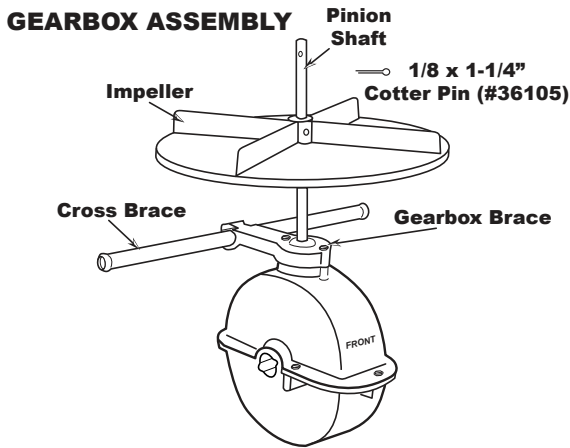

3. Install impeller onto pinion shaft. Insert 1/8" x 1 1/4" cotter pin through impeller then through pinion shaft. Use hole closest to the gear box. Spread cotter pin to prevent from falling out. Next insert Cross Brace thru the Gearbox Brace as shown above.

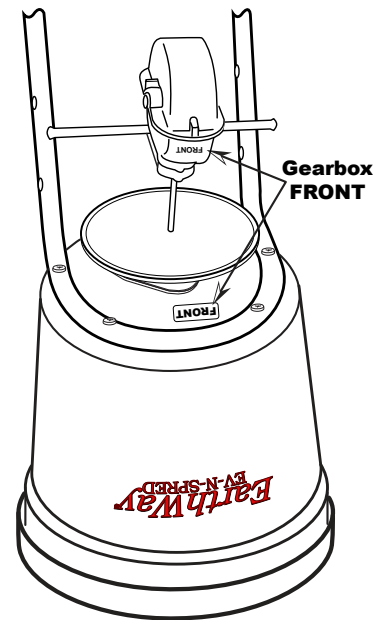

4. Install gearbox by inserting the pinion shaft into hole in center of hoppers bottom. The word "FRONT" on the gearbox must point to Front of the hopper. The EarthWay logo is on the front of the hopper.

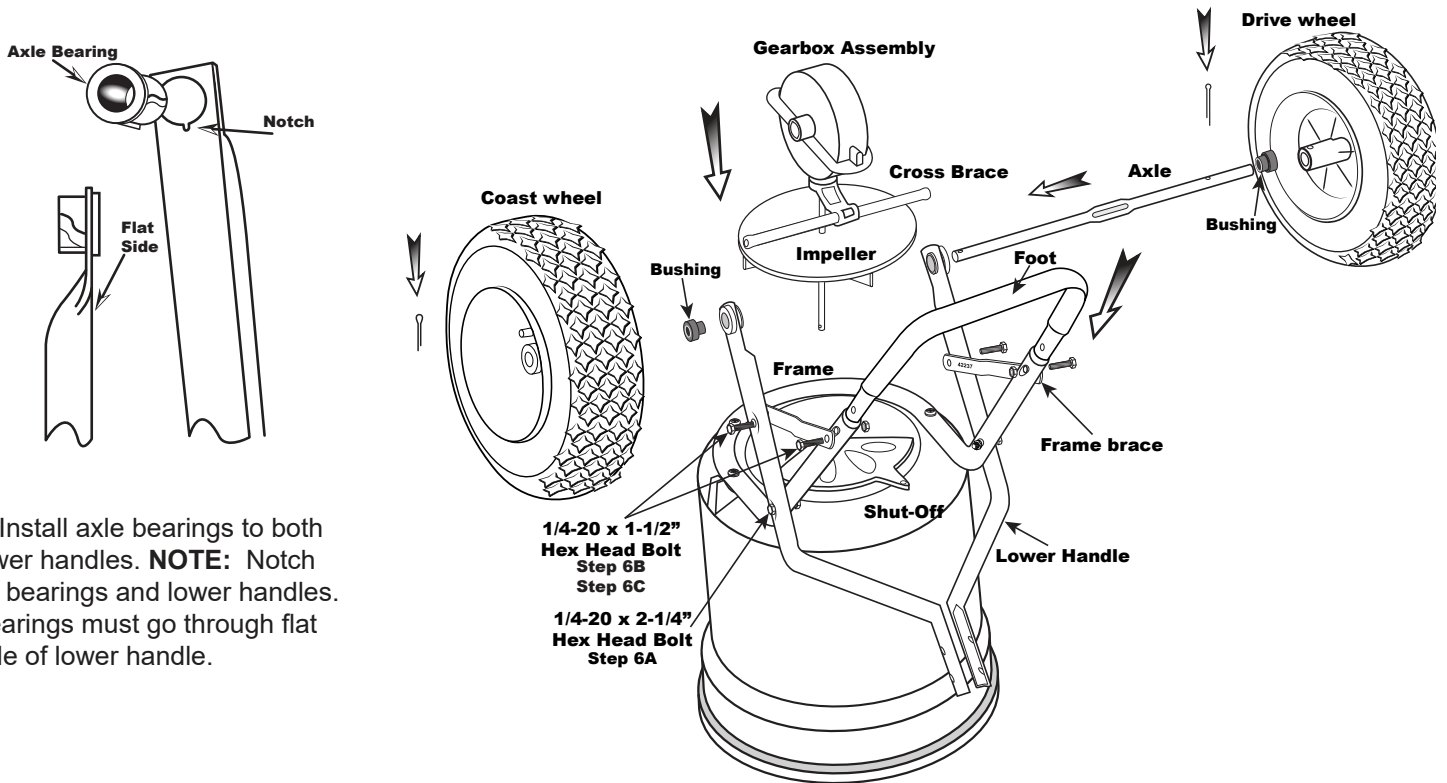

5. Install axle bearings to both lower handles. **NOTE:** Notch on bearings and lower handles. Bearings must go through flat side of lower handle.

6. **A** - Install lower handles onto frame to both sides as shown. Insert 2 1/4" bolt through second hole in lower handle and through first hole in frame install locknut. **DO NOT TIGHTEN.**

**B** - Now insert 1 1/2" bolt through first hole in lower handle, then through frame brace. **NOTE:** Numbers on frame brace must be facing toward gearbox as shown. Next into threaded connector in cross brace. **DO NOT TIGHTEN.**

Install the Foot into the Frame and align the bolt holes in the Foot and the Frame (a Phillips screwdriver or large nail is helpful to align the parts)

**C** - Next insert 1 1/2" bolt through other end of frame brace and through second hole in frame through the foot and install locknut.

**NOW GO BACK AND TIGHTEN ALL NUTS AND BOLTS STARTING WITH FIRST STEP.  
DO NOT OVER TIGHTEN.**

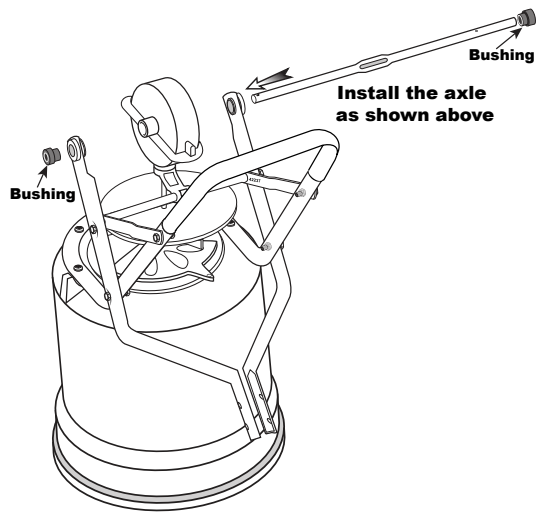

7. Slide axle into the lower handle, then the gearbox and into axle bearing on the other lower handle as shown above. Finally slide the bushings over the axle as shown above.

8. Install drive wheel onto the axle and align with the cotter pin hole nearest to lower handles as shown. Insert 2" cotter pin through wheel and through axle. Bend with pliers to prevent pin from falling out.

9. Install coast wheel onto the axle fully, then using outside cotter pin hole, insert 1" cotter pin through axle (**not thru the wheel**). Bend with pliers to prevent pin from falling out.

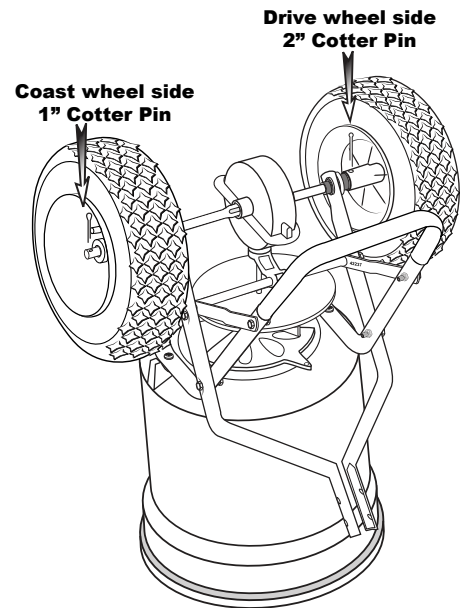

**TURN SPREADER UPRIGHT ON TO WHEELS.**

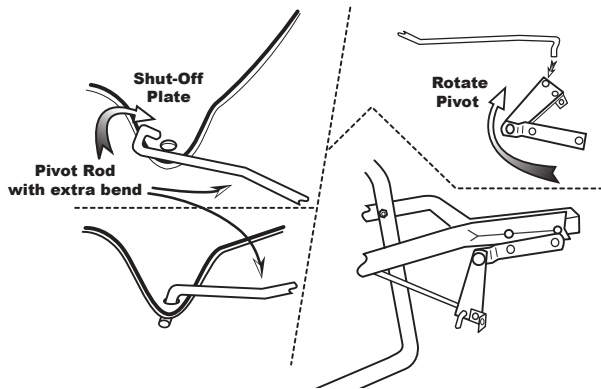

10. **NOTE:** BEFORE INSTALLING GAUGE AND UPPER HANDLES TO HANDLE SHAFT, UPPER HANDLES FEATURE TWO POSITIONS FOR OPERATOR'S COMFORT.

If operator chooses upper position, use handle spacer in hole nearest to handle grips.

Insert 2" bolt through upper handle, then through handle spacer through other upper handle and secure with locknut. **DO NOT TIGHTEN LOCKNUT YET. TIGHTEN THIS NUT LAST.**

Now slide the Upper Handle assembly over the Handle Shaft (**on the end with the bolt holes closer to the end**). Install gauge & lever using (2) 2" bolts. Be sure gauge is on left hand side. Tighten locknuts to gauge first. **TIGHTEN ALL HARDWARE NOW.**

11. Insert **Pivot Rod** into **Shut-Off Plate** as shown. Turn to lock in place.

12. Insert other end of **Pivot Rod** into **Pivot and Bracket** assembly as shown. Turn to lock in place.

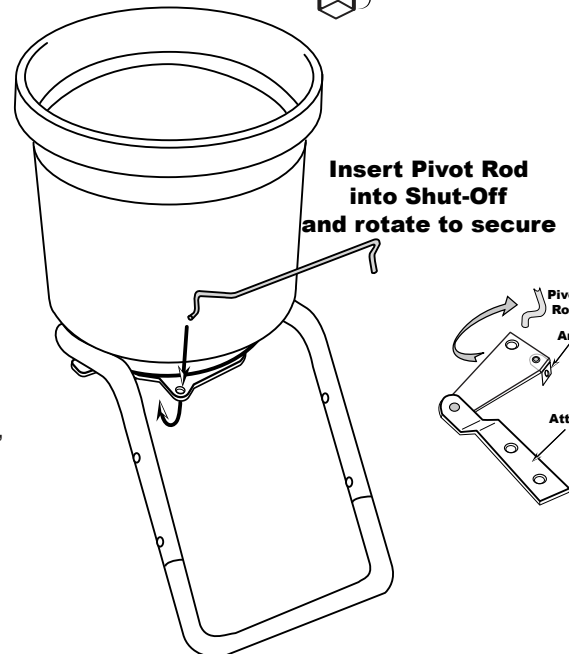
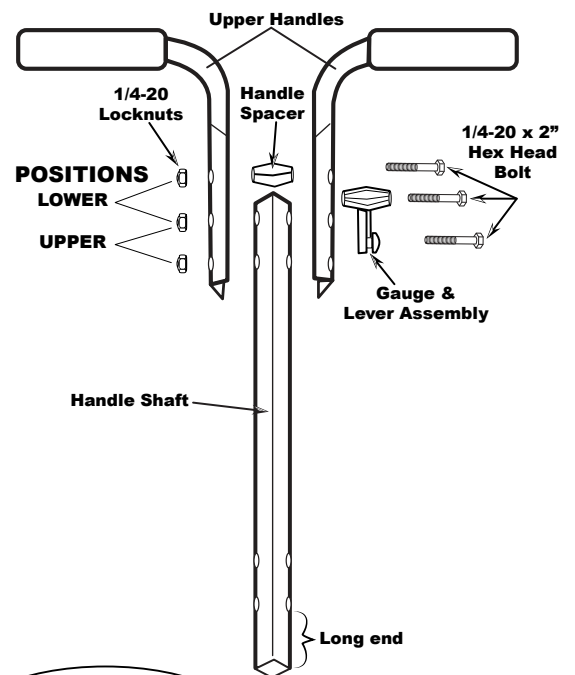

13. Install handle shaft to lower handles and pivot & bracket assembly as shown. Using 2" bolts and locknuts. **TIGHTEN BOLTS AND NUTS NOW.**

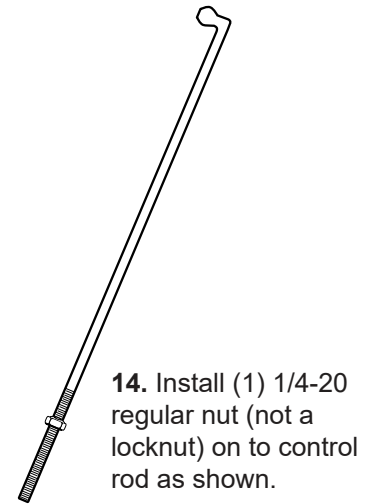
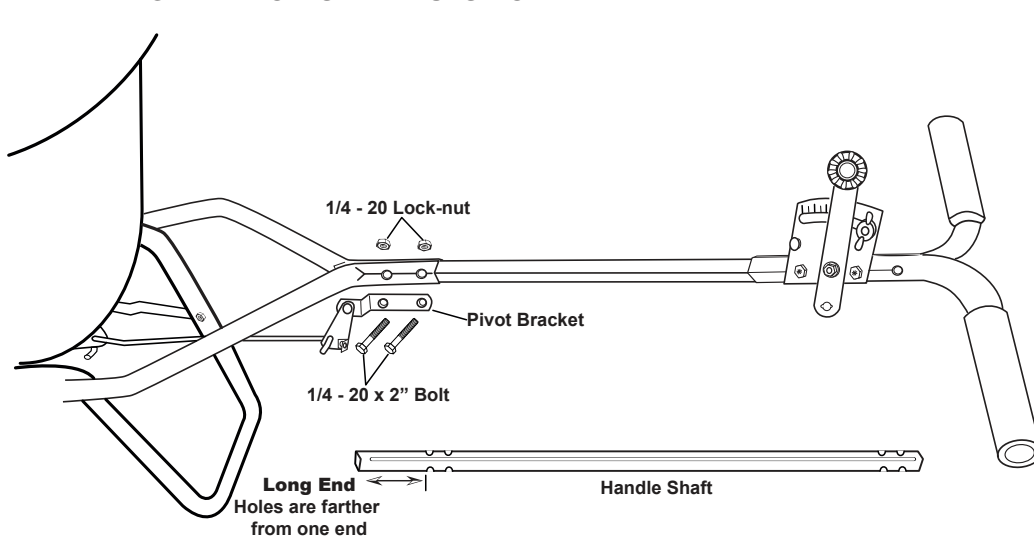

14. Install (1) 1/4-20 regular nut (not a locknut) on to control rod as shown.

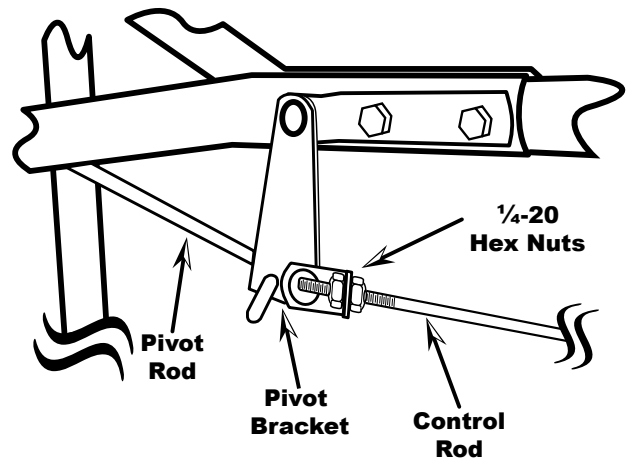
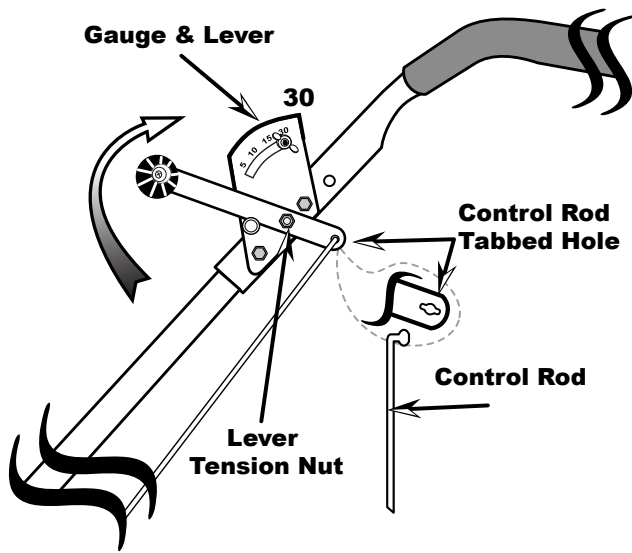

15. Install flattened end of control rod in to lever on gauge as shown. Turn to lock in place. Next push lever forward to setting "0". Align control rod with hole in pivot bracket, pull lever backward to insert control rod through hole in pivot bracket. Now install 1/4-20 regular nut on to control rod.

16. Pull lever back to setting "30" as shown. Next push pivot & bracket forward so that the shut off plate in the hopper is in the full open position. **REMEMBER SETTING "30" ON THE FLOW CONTROL LEVER MUST PLACE THE SHUT-OFF PLATE IN THE FULL OPEN POSITION TO BE PROPERLY CALIBRATED.** Now tighten the nuts against the pivot bracket to prevent change in calibration.

17. Tension on the flow control lever may be adjusted by tightening or loosening the tension nut as shown.

18. Insert agitator to pinion shaft on inside of hopper. **NOTE:** the position of flat side of the agitator in the drawing. The agitator should be installed as shown.

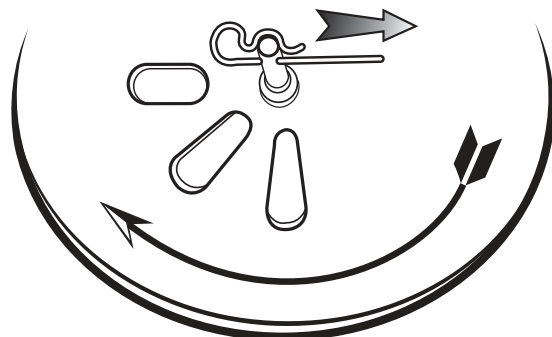

## **5-YEAR LIMITED WARRANTY**

Earthway Products, Inc. warrants this product free of defects in original workmanship and materials for a period of 5-years to the end user with the original purchase receipt. If a manufacturing non-conformance is found, Earthway Products, Inc. at its discretion will repair or replace the part(s) or product at no charge provided the failure is not the result of incorrect installation, mishandling, misuse, tampering, or normal wear and tear as determined by Earthway. Earthway at its discretion may require that the part(s) or product be returned along with the original purchase receipt at owners' expense for examination and compliance with the terms of this warranty. Do not return any product without first receiving authorization from Earthway Products, Inc. To seek remedy under this warranty, contact Earthway Products, Inc. at 574-848-7491, techsupport@earthway.com or write to Earthway Products, Inc. P.O. Box 547 Bristol, Indiana 46507 and describe the nature of the manufacturing defect. **SPECIFIC LIMITATIONS:** This warranty covers only the part(s) or product; any labor charges associated with repair or replacement of non-conformances are specifically excluded. Due to the corrosive nature of most fertilizers and ice melt products, Earthway Products, Inc. makes no warranty against and specifically excludes part(s) or product degradation or failure due to corrosion or its effects, or the use of powdered materials. Clean and dry your spreader thoroughly after each use, as a preventative measure, coat all metal parts with a light oil or silicon spray.

## **OPERATING INSTRUCTIONS**

Before filling hopper, become familiar with the operation of this spreader.

- Obtain proper setting for material to be used from the enclosed SETTING MATRIX included with this spreader, or from our web site under the MANUALS SECTION.
- Move stop bolt on rate gauge assembly to the proper setting.
- While pushing spreader forward, pull control lever back to stop bolt.
- To stop, push lever forward to close flow holes before you stop moving.
- When finished, empty any remaining material from hopper.
- Thoroughly wash spreader and allow to dry before storing. A coating of light oil will help prevent corrosion.
- If you use Rock Salt, remove agitator when in use to prevent damage to the gearbox.

The settings furnished on the **Rate Setting Matrix** are intended as a guide only. Variations in physical characteristics of material applied, walking speed, and roughness of ground surface may require slightly different spreader settings. Due to the above conditions, the manufacturer makes no warranty as to the uniformity of coverage actually obtained from the settings listed.

## **SPREAD PATH**

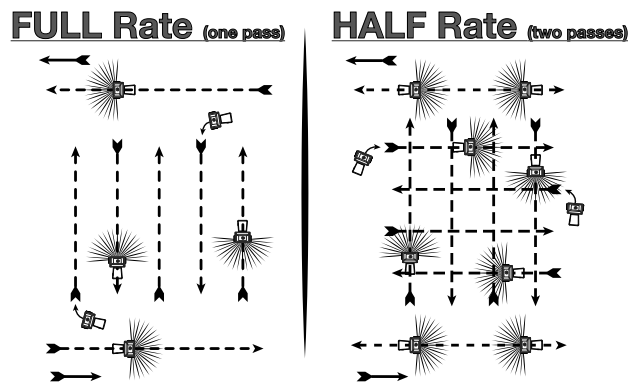

© 2015 Earthway Products, Inc. All rights reserved

## **HOW TO ORDER SPARE PARTS**

All spare parts listed herein may be ordered direct from the manufacturer. Be sure to give the following information when ordering.

- Model Number
- Part Number
- Part Description

You can contact us by calling (574) 848-7491 or 800-294-0671 to place an order with a credit card.

Or online at [www.earthway.com/parts](http://www.earthway.com/parts)

Questions? [Parts@earthway.com](mailto:Parts@earthway.com)

**Earthway Products, Inc.**  
P.O. Box 547  
Bristol, IN 46507  
Phone: 1-800-294-0671  
www.earthway.com

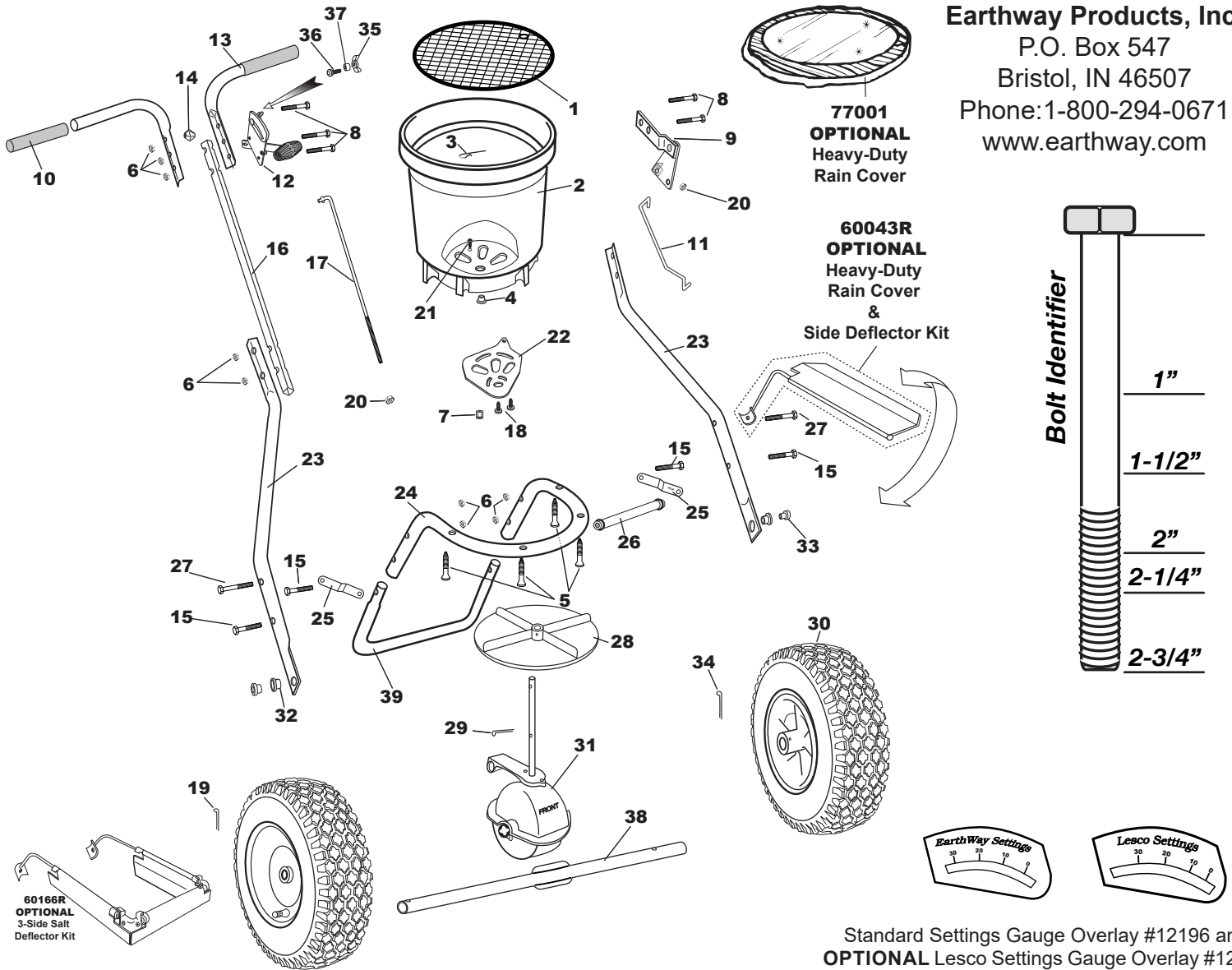

Standard Settings Gauge Overlay #12196 and  
**OPTIONAL** Lesco Settings Gauge Overlay #12195

## 2150 BROADCAST SPREADER ~ Parts List

KEY #	PART #	DESCRIPTION	KEY #	PART #	DESCRIPTION
1	40002	ROUND SCREEN	21	36208	#6 X 3/8" TYPE 25 PHPS S.S.
2	60332	HOPPER ASSEMBLY (2150/2150T)	22	12317	SHUT OFF PLATE (2600B) BLACK
3	33117	AGITATOR	23	25222	LOWER HANDLE SQ (2150's/2170's)
4	12220	GEAR BOX BUSHING (2050)	24	25108	FRAME (2150,2170,C22,C24,C25,F-Series)
5	31104	#14 X 1 1/2 TYPE 25 FHPS ZINC	25	44249	FRAME BRACE (2150/2170)
6	32103	1/4-20 NYLON INS LOCKNUT ZINC	26	25228	CROSS BRACE (2150/2170/S25) 11.25 REV908
7	11927	SHUTOFF SUPPORT- LARGE	27	31106	1/4-20 X 2 1/4" HHCS ZINC
8	31120	1/4-20 X 2" HHCS ZINC	28	12109	IMPELLER (9" DIA)
9	60300	PIVOT & BRACKET ASSEMBLY (2150/2170)	29	36105	1/8" X 1 1/4" COTTER PIN S.S.
10	12274	GRIP (2150/2170) 7.5" LONG	30	70138	PNEUMATIC DRIVE WHEEL STUD (2150/S25)
11	44251	PIVOT ROD (2150/2170/C22/C24)	31	60333	New Floating GEAR BOX (2150/C22)
12	60298	GAUGE & LEVER ASSEMBLY (2150/C22)	32	12148	AXLE BEARING (2130/2150/2170/S25)
13	60175	UPPER HANDLE SQUARE W/GRIP	33	12152	AXLE BUSHING (2130/2150/2170/S25)
14	12344	HANDLE SPACER (2150/2170) SQ.	34	33109	3/16" X 2" COTTER PIN ZINC
15	31100	1/4-20 X 1 1/2 HHMS ZINC	35	60027	WING NUT ASSEMBLY BLACK
16	25223	HANDLE SHAFT SQ (2150)	36	37100	1/4-20 X 1" CARRIAGE BOLT ZINC
17	42256	CONTROL ROD (2150/C24SS)	37	12147	SPACER (PIVOT LINK)
18	31138	#8 X 3/8" PMT #8 HD COARSE BLACK	38	24500	AXLE, COINED (2150, 2170, C, PUSH/TOW)
19	33108	3/16" X 1" COTTER PIN ZINC	39	25723	FRAME Foot (Flex-Select Painted)
20	32100	1/4-20 HEX NUT ZINC			

# Broadcast Setting Matrix

## Calibration Techniques

### How to ensure your spreader is properly calibrated

Make sure the drop holes in the bottom of the hopper are fully open when the Rate Control handle is on #30. If not, please adjust control cable or control rod to allow for a full open hopper position at #30.

### Rod Type Adjustment

1. Open the shut-off so that the drop holes are completely open as illustrated to the right.
2. Review the Control Lever position - if it is set so that the forward edge is at #30, you are calibrated. If not, you need to adjust the control rod at the pivot bracket shown in Fig 1.
  - A. If your shut-off is not able to open fully as in step #1. Loosen the top nut a few turns, then loosen the lower nut so that it allows you to push the shut-off open fully. Next tighten each nut so that they contact the pivot bracket without moving it, and then carefully tighten each nut fully so they do not loosen during use. Recheck adjustment as outlined in #1 above.
  - B. If your shut-off is able to open fully as in step #1, but the Control Lever is not at #30. Loosen the top nut a few turns, then loosen the lower nut so that it allows you to push the Control Lever to #30. Next tighten each nut so that they contact the pivot bracket without moving it. Carefully tighten each nut fully so they do not loosen during use. Recheck adjust as outlined in #1 above.

### Cable Type Adjustment

1. Open the Control Lever so that the shut-off and drop holes are completely open as illustrated above right.
2. Review the Control Lever position so that the indicator is pointed to #30, if it is your calibration is correct. If not you need to adjust the control cable at the cable clamp on the underside of the hopper as shown in Fig 2.
  - A. If your shut-off is not able to open fully as in step #1. Loosen the cable clamp screw slightly so that you can slide the outer cable out so that the shut-off is fully open. Next tighten the cable clamp screw securely. Recheck adjustment as outlined in #1 above.
  - B. If your shut-off is able to open fully as in step #1, but the Control Lever is not at #30. Loosen the cable clamp screw slightly so that you can slide the outer cable in so that the Control Lever opens to #30. Next tighten the cable clamp screw securely. Recheck adjustment as outlined in #1 above.

If you have any questions regarding the operation or assembly of your spreader please call us at 800-294-0671 or 574-848-7491 Monday - Friday 9:00am - 4:00pm Eastern. **Accessories and Repair Parts** are also available at these numbers.

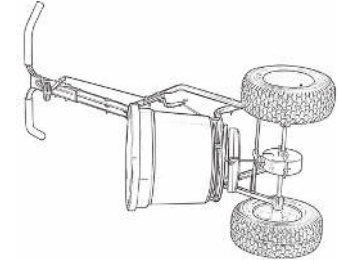
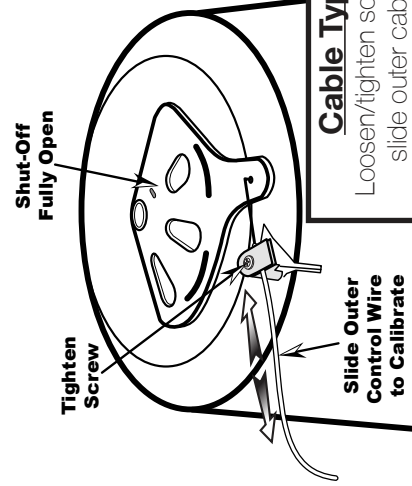
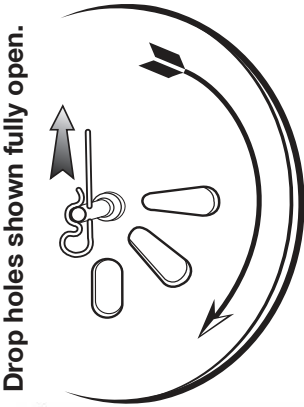
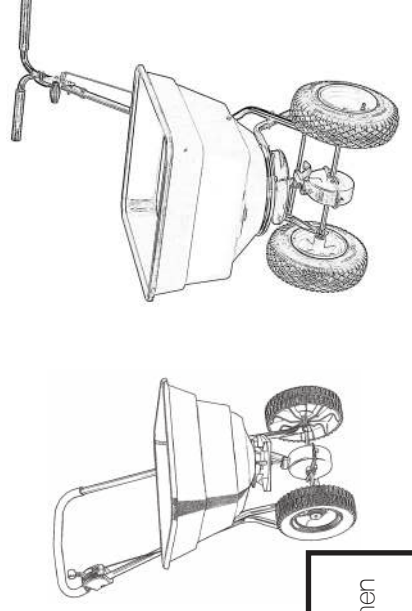
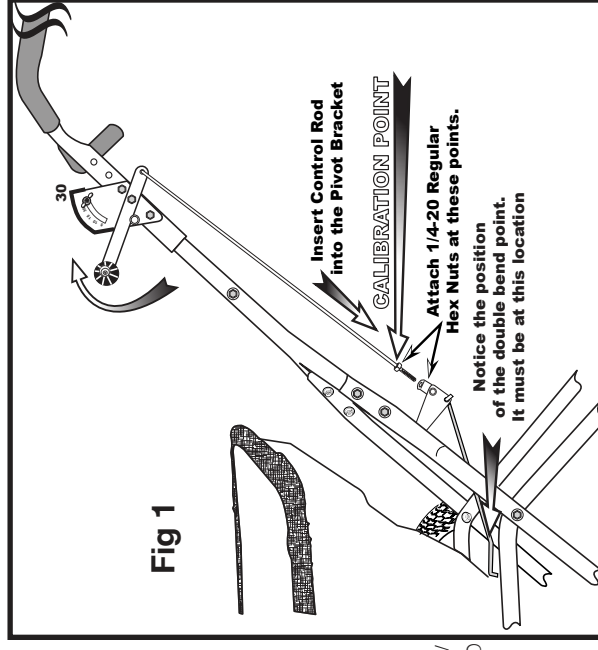

Fig 2

## ESTABLISHING A SETTING RATE

**Step 1:** Use **Chart 1** to estimate the number of LBS/1,000 square feet of coverage (Example: 20 LB. bag with 10,000 square foot coverage = 2.0 LBS/1,000 square feet)

**Step 2:** Find the closest LBS/1,000 square feet in **Chart 2** that you estimated using **Chart 1** (Example: 2.0 LBS/1,000 square feet = Spreader Setting of 13)

**Step 3:** Determine the Spread Width by evaluating the particle or seed size in

**Chart 3** to determine the Spread Width between Spread Paths

CHART 1	BAG COVERAGE IN SQUARE FEET		
	5,000	10,000	15,000
	LBS/1,000 SQ FT		
B	1.0	0.5	0.3
A	2.0	1.0	0.7
G	3.0	1.5	1.0
	3.6	1.8	1.2
W	4.0	2.0	1.3
E	5.0	2.5	1.7
I	6.0	3.0	2.0
G	7.0	3.5	2.3
H	8.0	4.0	2.7
T	9.0	4.5	3.0
	10.0	5.0	3.3

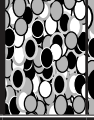

CHART 2		
GRAMS/SQ METER	LBS./1,000 SQ FT	SPREADER SETTING
5 Grams	1.0 LBS.	11
10 Grams	2.0 LBS.	13
15 Grams	3.0 LBS.	14
20 Grams	4.0 LBS.	16
25 Grams	5.0 LBS.	17
30 Grams	6.0 LBS.	18
35 Grams	7.0 LBS.	19
40 Grams	8.0 LBS.	20
45 Grams	9.0 LBS.	22
50 Grams	10.0 LBS.	23

## METRIC RATE SETTING



### Determining a Setting Rate

Use chart below to determine the **Setting Rate** based on **Grams/Square Meter** of coverage as directed on the bag.

**All spread widths are determined by particle size and weight.**

CHART 3		
SPREAD WIDTHS FOR DIFFERENT PARTICLE SIZES		
Particle Size	English	Metric
	5-7ft.	1.5-2.1m
	7-9ft.	2.1-2.7m
	9-12ft.	2.7-3.7m

SPREAD WIDTH FOR DIFFERENT SIZE GRASS SEED		
Seed Size	English	Metric
	5-7ft.	1.5-2.1m
	7-10ft.	2.1-3.1m

## SPREAD PATHS

### FULL Rate (one pass)

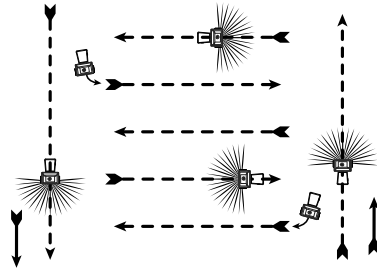

### HALF Rate (two passes)

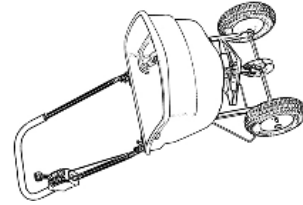
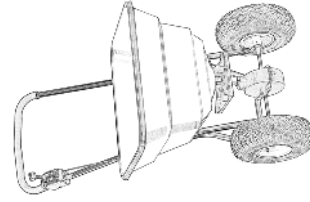
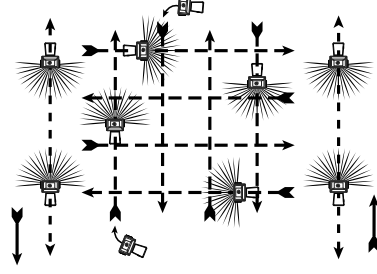

**Maintain a consistent walking speed of 2-3mph or the application rate will change.**

© 2014 Earthway Products, Inc. All rights reserved

The settings furnished on the Rate Setting Matrix are intended as a guide only. Variations in physical characteristics of material applied, walking speed, and roughness of ground surface may require slightly different spreader settings. Due to the above conditions, EPI makes no warranty as to the uniformity of coverage actually obtained from the settings listed.